

LINDSEY EMERGENCY RESTORATION SYSTEM

Technical Feasibility Study Information and Data Worksheet

After completely filling out this 6-page information and data worksheet, return this by **E-mail** or facsimile transmission to:

Lindsey Manufacturing Company
P.O. Box 877,
760 N. Georgia Ave.
Azusa, CA 91702 USA
www.lindsey-usa.com
Telephone: 001 626-969-3471
Fax: 001 626-969-3177
E-mail: mail@lindsey-usa.com

If you have additional questions, you may contact us by either phone, fax or e-mail. An example is given on pages 7 and 8.

When ready, the ERS Technical Feasibility Study should be sent to the following person: (Please fill in all yellow boxes)

Name:				
Title:				
Company:				
Type of Business: (Check)	Electric Utility		Manufacturer	
	Consultant		Contractor	
	Agent/Representative		Other	
Mailing Address:				
	Country:			
Phone:		Fax:		
E-mail:				

Technical Feasibility Study Information and Data Worksheet

The following information will be used to prepare a technical feasibility proposal for the Lindsey Emergency Restoration System (ERS). The information requested in this questionnaire is the minimum required for assembling a proposal. A worksheet should be prepared for each voltage level as well as for each critical line. Any additional information or expansion on any item would be beneficial.

How to Complete This Form: Fill in each yellow box below with the appropriate number. If there are two boxes, fill in the first box with a number and the second box with a unit of measure.

For example:

Conductor Weight	1.35	Kg/m
-------------------------	------	------

1. General Information

Transmission Line Voltage				kV, line to line	
Structure Type ("X" one or more of A through F, see sketches below)					
A		B		C	
D		E		F	
Typical or Average Conductor Height at Tower ("X" below)					

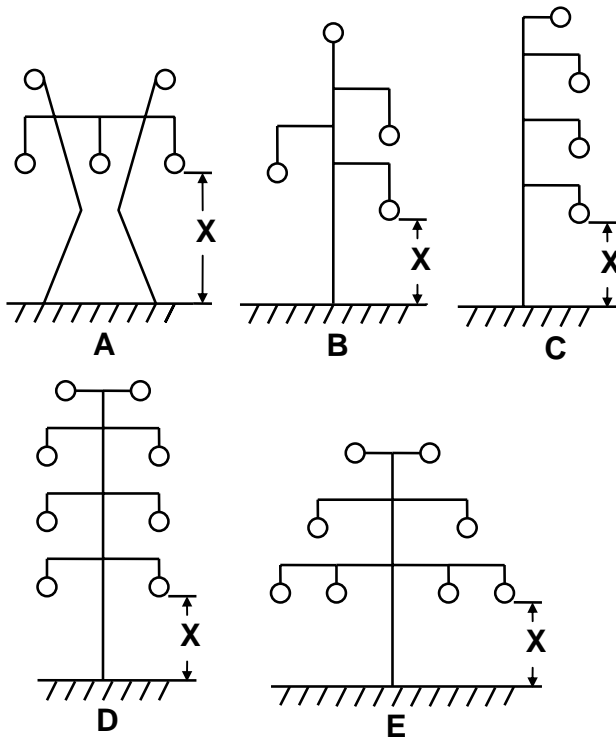

F (Other, make sketch and Fax)

2. Failure Scenarios

Fill in one or more of the failure scenarios below that you would like to have analyzed.

A. Tangent Suspension Tower Failure Scenario:

Number of Suspension Towers Destroyed *		
Number of Circuits to be Restored (1 or 2)		
Typical Span Length Between Towers		

*Note: When one suspension tower is destroyed, we will assume damage to the two adjacent structures

B. Angle or Tension Tower Failure Scenario:

Total Line Angle at the Tower (Degrees) *		
Number of Circuits to be Restored (1 or 2)		
Typical Span Length Between Towers		

*Note: When one angle tower is destroyed, we will assume damage to the two adjacent structures

C. Other Failure Scenarios: (Describe and/or sketch additional failure scenarios below.)

Example:

Double circuit 15° line angle tower destroyed with 420m and 350m spans to adjacent suspension towers that are damaged. One circuit to be restored.

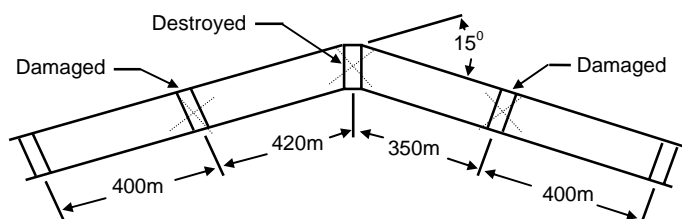

3. Conductor and Overhead Shield Wire Data

Note: If the Shield Wire is not needed leave the Shield Wire yellow boxes blank

Conductor Name or Description:	
Number of Sub-Conductors per Phase (i.e.: 1, 2, 3 or 4)	

<i>Required Data</i>	Conductor		Shield Wire	
Diameter				
Weight per Unit Length (i.e.: kg/m)				

4. Insulation

Typically, the level of insulation on the Emergency Restoration Structure (ERS) is less than on a permanent structure since long term contamination performance is not required. Check below the Leakage Distance Requirements for the ERS Structure. Include any special requirements (Altitude, etc) in question 8.

Recommended Specific Leakage IEC Publication 815 (mm/kV _{phase-phase})		North American Practice ANSI Standard 985 (in/kV _{phase-ground})		CHECK ONE
Level I	16	Light	1"	
Level II	20	Medium	1.25"	
Level III	25	High	1.5-1.75"	
Level IV	31	Very High	2"	

5. Loading Parameters

The loading criteria for the Emergency Structure should consider the length of time that the structure will be in service. Designing for a 50 to 100 year return storm may limit the structure, while a 10 or 25 year return storm may be more realistic. Typically, either a heavy vertical load (ice) or a horizontal wind load will control the design of the Emergency Structure.

	Case I Heavy Vertical		Case II Wind	
Radial Ice Thickness*				
Wind Speed or Pressure on Conductor				
Sub-Conductor Tension				
Shield Wire Tension				
Wind Speed or Pressure on One Face of the ERS Structure				

*Note: A relative Ice Density of 0.914 is assumed unless specified otherwise in Section 8.

5. Loading Parameters (Continued)

	Case I Heavy Vertical	Case II Wind
Vertical Overload Safety Factor		
Horizontal Overload Safety Factor		
Tension Overload Safety Factor		

6. Soil and Anchoring Conditions

Indicate the approximate percentage of the type of soil encountered along the transmission line right-of-ways. Also indicate if anchors should be supplied for these locations, and if so your preference.

Type of Soil	%
Sound Hard Rock	
Normal: Medium Dense Clay	
Peat, Swamp or Wet Lands	
Total	100%

Type of Anchors to be Supplied with ERS	YES	NO
Rock Anchors with Hydraulic Rock Drill and Accessories		
Manta-Ray Anchors with Hydraulic Jack Hammer and Accessories		
Manually Installed Buried Cross Plate Anchors		
Swamp Type Helix Screw Anchors for Manual or Truck Installation		
Other:		

Other Comments on Soils or Requirements for Anchoring:

7. Methods of Construction

Check the method(s) that will need to be used in constructing the ERS. This will help determine the accessories and additional tools required with a complete system.

Construction Method	Most Likely Used All of the Time	Will Need to be Used in a few Special Cases
Manual Labor Only		
Small Truck Mounted Cranes and Winches		
Large Cranes		
Helicopters		

Additional comments on preferred/required methods of construction:

8. Additional Information

Indicate any special circumstances, requirements or limitations that should be considered when planning an Emergency Restoration System. This information might include right-of-way constraints, special terrain problems, equipment limitations, desired brand of polymers insulators, etc.

EXAMPLE

1. General Information

Transmission Line Voltage	400		kV, line to line	
Structure Type ("X" one or more of A through F, see sketches below)				
A	X	B	X	C
Typical or Average Conductor Height at Tower ("X" below)				
			30	m

2. Failure Scenarios

A. Tangent Suspension Tower Failure Scenario:

Number of Suspension Towers Destroyed *	4
Number of Circuits to be Restored (1 or 2)	1
Typical Span Length Between Towers	375
	m

*Note: When one suspension tower is destroyed, we will assume damage to the two adjacent structures

B. Angle or Tension Tower Failure Scenario:

Total Line Angle at the Tower (Degrees) *	30
Number of Circuits to be Restored (1 or 2)	1
Typical Span Length Between Towers	375
	m

3. Conductor and Overhead Shield Wire Data

Conductor Name or Description:	ASTR 570
Number of Sub-Conductors per Phase (i.e.: 1, 2, 3 or 4)	2

<i>Required Data</i>	Conductor		Shield Wire	
Diameter	3.105	mm		
Weight per Unit Length (i.e.: kg/m)	1.574	Kg/m		

4. Insulation

Recommended Specific Leakage IEC Publication 815 (mm/kV phase-phase)		North American Practice ANSI Standard 985 (in/kV phase-ground)		CHECK ONE
Level II	20	Medium	1.25"	X

5. Loading Parameters

	Case I Heavy Vertical		Case II Wind	
Radial Ice Thickness*	2	cm	0	
Wind Speed or Pressure on Conductor	180	Pa	570	Pa
Sub-Conductor Tension	42.9	kN	27.5	kN
Shield Wire Tension				
Wind Speed or Pressure on One Face of the ERS Structure	300	Pa	1200	Pa

	Case I Heavy Vertical	Case II Wind
Vertical Overload Safety Factor	1.5	1.5
Horizontal Overload Safety Factor	1.5	1.5
Tension Overload Safety Factor	1.5	1.5

6. Soil and Anchoring Conditions

Type of Soil	%
Sound Hard Rock	5
Normal: Medium Dense Clay	80
Peat, Swamp or Wet Lands	15
Total	100%

Type of Anchors to be Supplied with ERS	YES	NO
Rock Anchors with Hydraulic Rock Drill and Accessories		X
Manta-Ray Anchors with Hydraulic Jack Hammer and Accessories	X	
Manually Installed Buried Cross Plate Anchors		X
Swamp Type Helix Screw Anchors for Manual or Truck Installation	X	

7. Methods of Construction

Construction Method	Most Likely Used All of the Time	Will Need to be Used in a few Special Cases
Manual Labor Only		X
Small Truck Mounted Cranes and Winches	X	
Large Cranes		
Helicopters		X