

# TRANSMISSION LINE RESTORATION TECHNIQUES IN COLOMBIA, SOUTH AMERICA

**Mario Aristizabal**  
Transmission Line Engineer  
Interconexión Eléctrica SA  
Medellin, Colombia, South America

**Sergio Cortez**  
Project Engineer  
Lindsey Manufacturing Company  
Azusa, California, USA

## Abstract

This paper documents the transmission line emergency restoration experiences and practices of the Colombian National Interconnection System. In addition to natural disasters, emergencies caused by vandalism and sabotage have become frequent occurrences. Various techniques developed to rapidly and efficiently restore service after an emergency are presented along with an overview of the emergency restoration philosophy in Colombia, South America.

## 1. Introduction

Interconexión Eléctrica SA (ISA) is a power supplier in Colombia who's primary responsibility is the construction and maintenance of the National Interconnection System (Figure 1). ISA operates over 500km of single circuit 500kV lines, over 2000km of single and double circuit 230kV lines and a small amount of lower voltage lines. Present plans call for the addition of over 500km of single circuit 500kV lines and over 700km of single and double circuit 230kV lines during 1993.

The terrain of Colombia is dominated by the Andes mountains and consequently a very high percentage of the

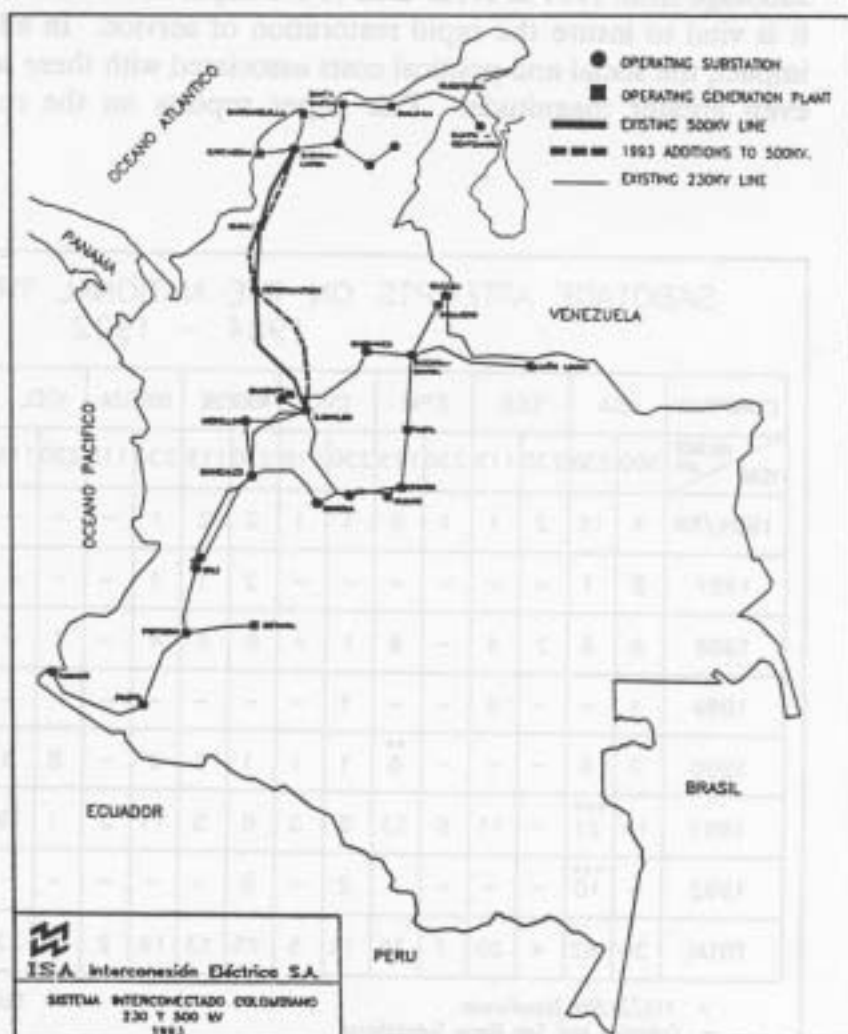

**Figure 1**

*The National Interconnection System of Colombia*

transmission lines traverse extremely harsh and difficult areas. ISA uses mostly self-supporting, steel lattice towers and a vast majority of these are located in remote and inaccessible locations with altitudes reaching 4000M.

Like any transmission system, the Colombian system is occasionally affected by natural disasters. Erosion of footings, land slides, flooding, rivers changing course and coastal tower leg corrosion are all problems faced by ISA. Since 1984, however, the predominate cause of tower failures in Colombia has been acts of sabotage. Colombian guerrillas have dynamited numerous towers, causing severe disruption to the National Interconnection System.

Early sabotage attempts were frequently unable to bring down the transmission towers. The guerrillas steadily improved their technology, however, until they could successfully fail towers on a regular basis. The most recent attacks have targeted multiple towers on the same line to further increase the difficulty of restoration.

The growth and magnitude of these sabotage attacks can be seen in Figure 2, showing the total number of towers lost by ISA and the other major utilities in Colombia due to acts of sabotage from 1984 to 1992. Due to the importance of the National Interconnection System it is vital to insure the rapid restoration of service. In addition to the obvious economic impact, the social and political costs associated with these service interruptions are often of even greater magnitude. This paper reports on the restoration experiences with the

COMPANY	ISA		EEB		EPM		CVC		NORDESTE		CORELCA		ICEL		TOLIMA	CHEC	EADE	TOTAL
	500	230	230	115	230	115	230	115	230	115	230	115	230	115	115	115	115	
YEAR																		
1984/86	4	16	2	1	1	6	1	1	2	2	1	-	-	-	5	-	8	50
1987	2	1	-	-	-	-	-	-	2	1	1	-	-	-	-	-	-	7
1988	8	8	2	4	-	6	1	*	6	4	4	-	1	-	1	2	1	48
1989	1	-	-	4	-	-	1	-	-	-	-	-	-	-	-	-	-	6
1990	7	6	-	-	-	**	6	1	1	1	1	2	-	8	3	-	-	36
1991	14	***	-	11	6	13	5	3	6	5	11	2	1	19	-	2	7	126
1992	-	***	-	-	-	4	2	-	8	-	-	-	-	-	-	-	-	24
TOTAL	36	62	4	20	7	35	11	5	25	13	19	2	10	22	6	4	16	297

\* 115/34.5kV Transformer  
 \*\* Colombia and San Diego Substations  
 \*\*\* Jaguas Hydroelectric

Note: In 1991-1992, during construction of the second 500kV line, 16 towers were sabotaged.

Figure 2

National Interconnection System and presents the general methodology used by ISA for the rapid restoration of transmission lines.

## 2. History

Until 1984, most transmission line emergencies occurred as a result of natural disasters. Restoration was accomplished using available spare towers or wood poles. In 1984, guerrillas began to dynamite transmission tower legs. Since these early attempts did not cause the complete collapse of towers, it was only necessary to repair and reinforce the damaged legs. By 1985 the sabotage techniques had improved to the point where complete towers were being destroyed.

In 1986, ISA acquired modular, aluminum emergency restoration structures. After training and field practice, these structures were placed in service for 230 and 500kV line restoration. From 1986 to 1990, ISA used the aluminum restoration structures extensively for restoration of towers on their own lines as well as the lines of neighboring electric companies. In 1990, due to the increased guerilla activity, ISA acquired additional aluminum restoration structures. In 1992 alone, these aluminum restoration structures were used to restore eighteen 500kV towers and ten 230kV towers.

## 3. Restoration Techniques

ISA has developed a number of techniques to deal with the loss of towers on the transmission line. These techniques were developed to overcome the difficult terrain and limited access at a majority of the tower locations.

### 3.1 Restoration of Damages Caused by Natural Phenomena

In a number of areas, problems with soil erosion and landslides have made it necessary to reroute the transmission line around problem areas (Figure 3). In less severe cases, wood, concrete and metallic retaining walls have been constructed to stabilize the area around tower footings. ISA has also planted new vegetation and built special drainage ducts on some slopes in an attempt to stabilize the soil.

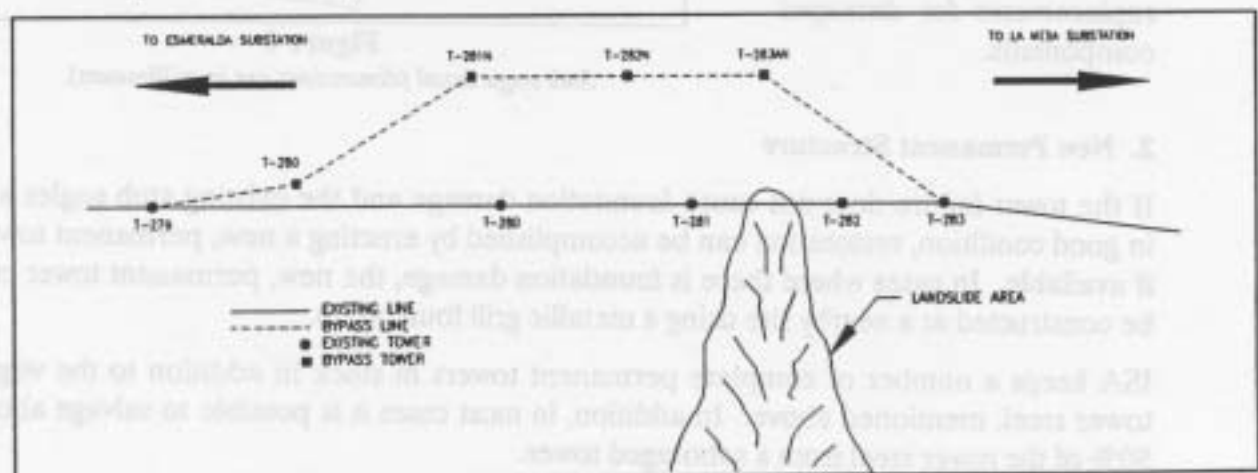

**Figure 3**

*Due to a landslide affecting the stability of Tower 281, a bypass restoration was built.*

### 3.2 Restoration of Damages Caused by Acts of Vandalism

There are three basic methods for restoration of lost or damaged towers. The method chosen varies depending on the extent of the damage and the materials available.

#### 1. Repair the Structure

In cases where the damage to a structure is not sufficient to cause complete collapse, restoration can be accomplished by repairing the damaged tower steel. ISA constructs the tower stub angles with a spliced connection in the upper portion of the footings (Figure 4). With this type of construction, repair can be accomplished by chipping away only the upper portion of the footing and replacing the damaged stub angle. ISA also maintains a supply of virgin tower steel, particularly material that is not readily available in Colombia, to rapidly fabricate replacements for damaged components.

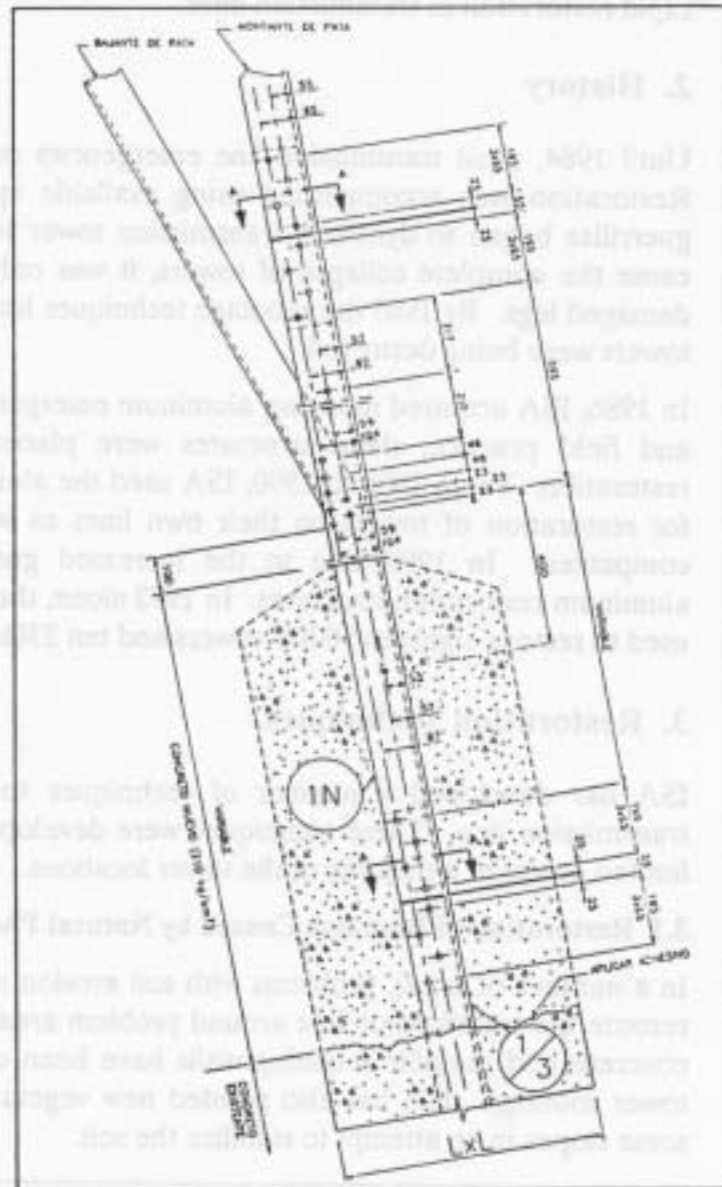

**Figure 4**

*Stub angle detail (dimensions are in millimeters).*

#### 2. New Permanent Structure

If the tower failure does not cause foundation damage and the existing stub angles are in good condition, restoration can be accomplished by erecting a new, permanent tower if available. In cases where there is foundation damage, the new, permanent tower can be constructed at a nearby site using a metallic grill foundation.

ISA keeps a number of complete permanent towers in stock in addition to the virgin tower steel, mentioned above. In addition, in most cases it is possible to salvage about 50% of the tower steel from a sabotaged tower.

### 3. Temporary Restoration

In most cases it is necessary to initially restore service in a temporary fashion. Later, when system loading allows and replacement material is available, permanent restoration can be done. In making a temporary restoration there are a number of options that can be considered and used to greatly speed up the restoration.

#### Utilization of the Collapsed Tower

One of the first alternatives considered, especially at remote and inaccessible tower sites, is to leave as many phases as possible in service on the downed tower. For example, on double circuit towers that fall transversely, the upper circuit can often be left in service. On a single circuit tower, one and sometimes two phases can be left on the failed tower and reenergized, with only the one phase actually in contact with the ground being moved to a temporary structure (Figure 5). In some cases, fiberglass rods or insulators are used to limit the conductor motion and insure that all required clearances are maintained. If needed, the collapsed tower is stabilized with guy wires.

#### Tower Configuration Alterations

In many cases it is necessary to make modifications with the temporary towers from the permanent installation. For example, the deadend strings of a tension tower may be brought together and made into a suspension tower or a running angle. When restoring the 500kV line, which is a four bundle design, there have been occasions where the temporary restoration was done with a two bundle with only a slight limitation on the line's capability. Frequently, the OHGW is eliminated in the damaged section in order to accelerate the temporary restoration .

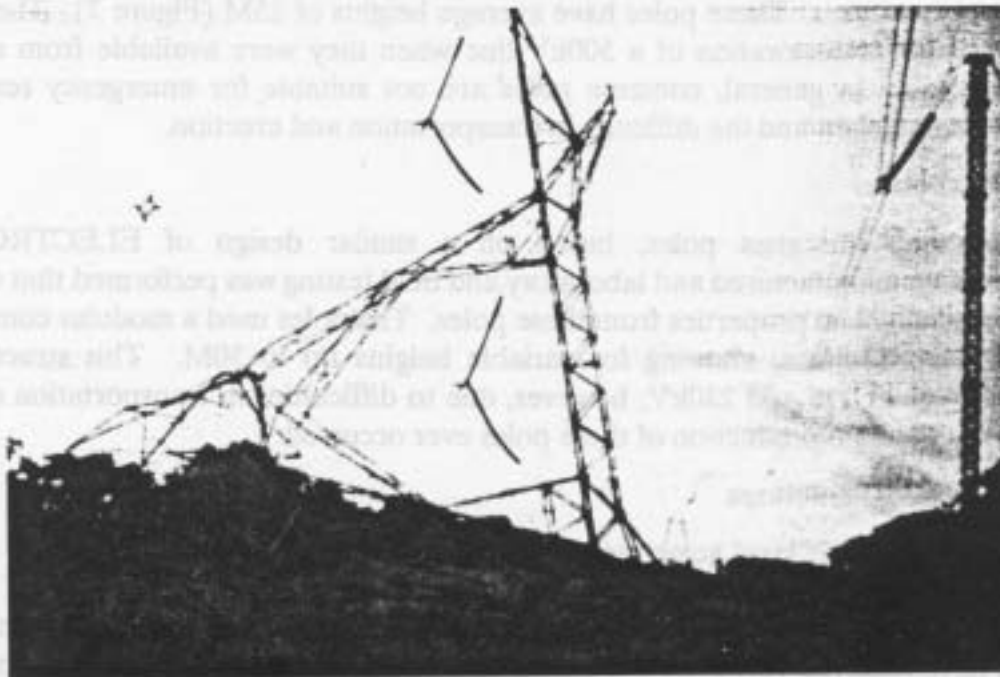

**Figure 5**

*Utilization of the collapsed tower for temporary restoration.*

### **Final Restoration**

When service is initially restored on a temporary basis, it is necessary to later return and perform permanent restoration. Planning for this final restoration actually begins during the temporary restoration. When the temporary towers are located, the area around the permanent tower site is left clear to allow work to be proceed safely. In cases where the collapsed tower was used in the temporary restoration, additional temporary structures are erected and the conductors transferred to allow dismantling of the damaged tower and rebuilding of the replacement structure. Once the new, permanent tower has been erected, the conductors are transferred from the temporary tower, which is then removed.

## **4. Evaluation of Various Temporary Structures**

ISA has studied a number of types of temporary towers to insure that service can be restored quickly and efficiently. These various tower types are described below.

### **4.1 Wood Poles**

Wood poles are frequently used for 115kV lines, generally in a horizontal vee configuration. These poles have a maximum height of 16M and average spans of 80M. For 230kV lines a special H-Frame structure has been designed using poles of 12 and 18M to achieve a structure height of 21 and 28M (Figure 6). Although wood poles are the least expensive alternative, they have relatively limited capacity and they can create transportation and handling problems in the mountainous regions.

### **4.2 Concrete Poles**

Concrete poles are used on 115 and 230kV lines where adequate access roads are available to allow transportation. These poles have average heights of 15M (Figure 7). These poles were once used for restoration of a 500kV line when they were available from a nearby construction job. In general, concrete poles are not suitable for emergency restoration because of their weight and the difficulty in transportation and erection.

### **4.3 Fiberglass Poles**

ISA investigated fiberglass poles, based on a similar design of ELECTROPERU. Prototypes were manufactured and laboratory and field testing was performed that achieved the desired mechanical properties from these poles. The poles used a modular construction consisting of six sections, allowing for variable heights up to 30M. This structure was intended for use at 115 and 230kV; however, due to difficulties in transportation and field assembly, no full-scale production of these poles ever occurred.

### **4.4 Modular Steel Structures**

A lattice type, modular steel structure was designed and built in Colombia. The modular sections are 4.3M in length, with a maximum structure height of 34M (Figure 8). Column sections are mounted on a hinged base plate, allowing rotation in one direction. These structures have received very little use due to their lack of flexibility and the low confidence in their reliability.

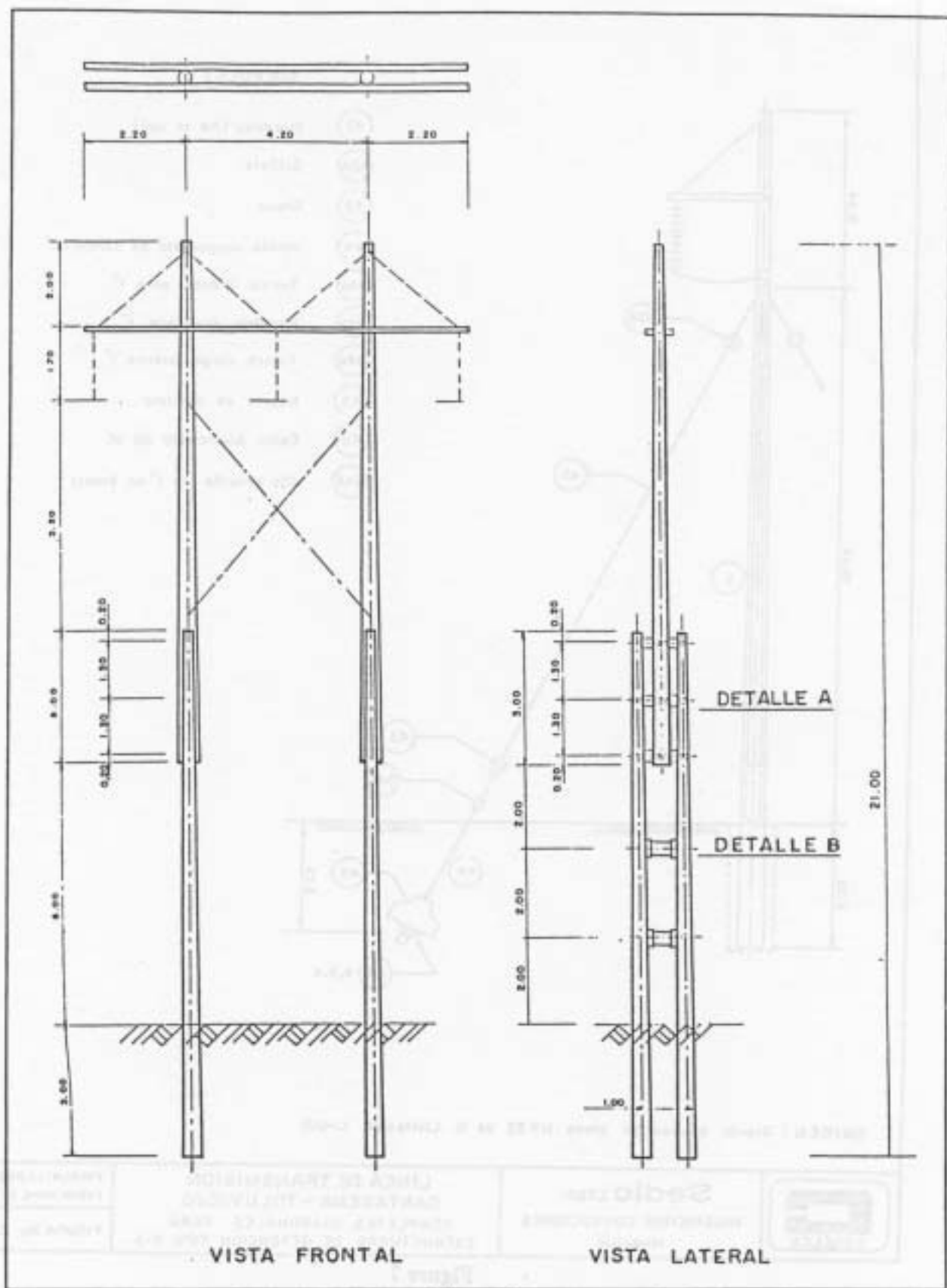

**Figure 6**

*Wood Pole H-Frame Structure (dimensions in meters).*

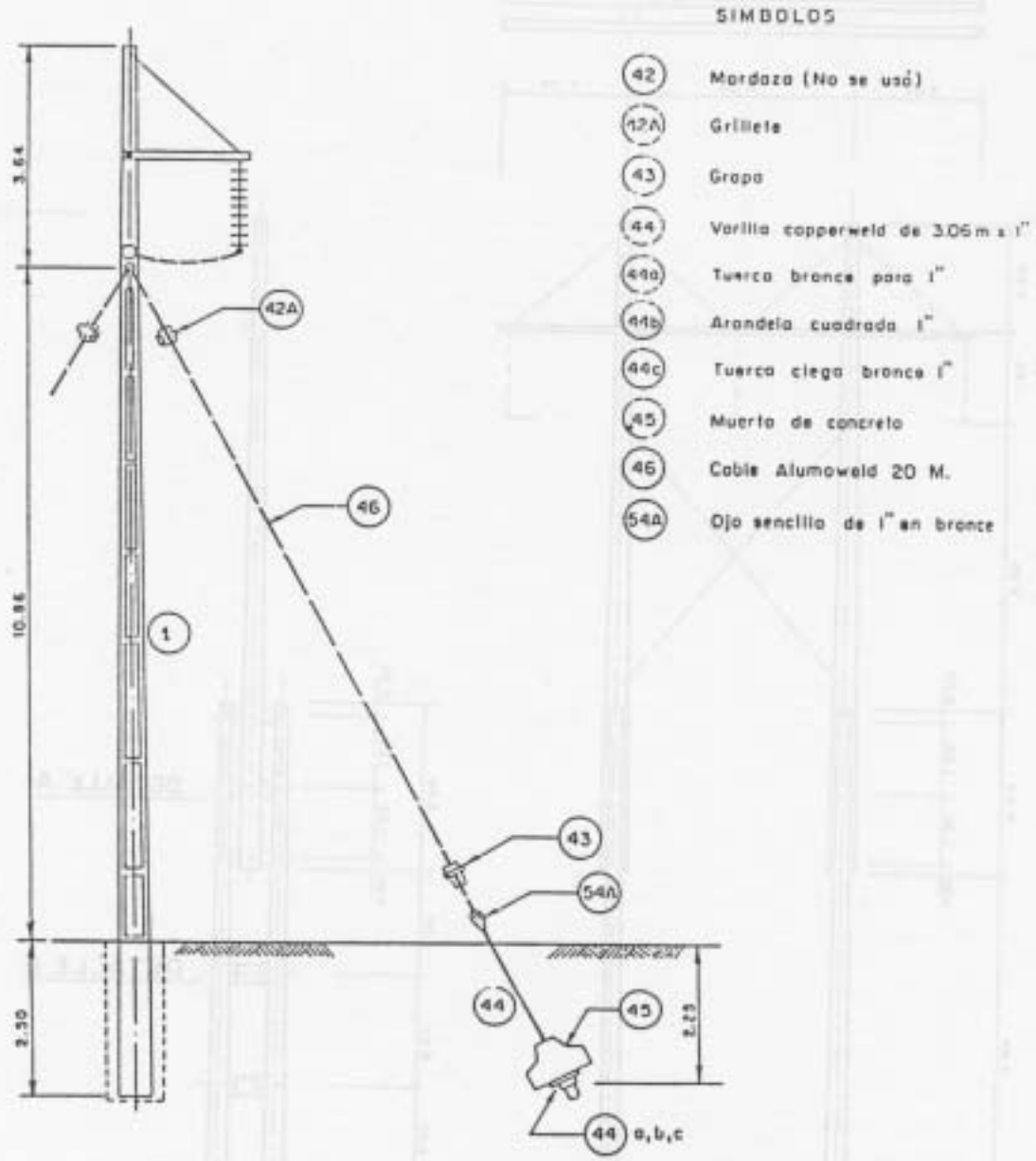

ORIGEN : Dibujo basado en plano N° 32 de la Licitación C-031

	<b>Sedic</b> LTDA. INGENIEROS CONSULTORES Medellín	LINEA DE TRANSMISION CARTAGENA - TOLUVIEJO TEMPLETES DIAGONALES PARA ESTRUCTURAS DE RETENCION TIPO R-3	ESCALA: 1:1.000 FECHA: ABRIL DE 1977
			FIGURA No. 23

**Figure 7**

Concrete Structure (dimensions in meters).

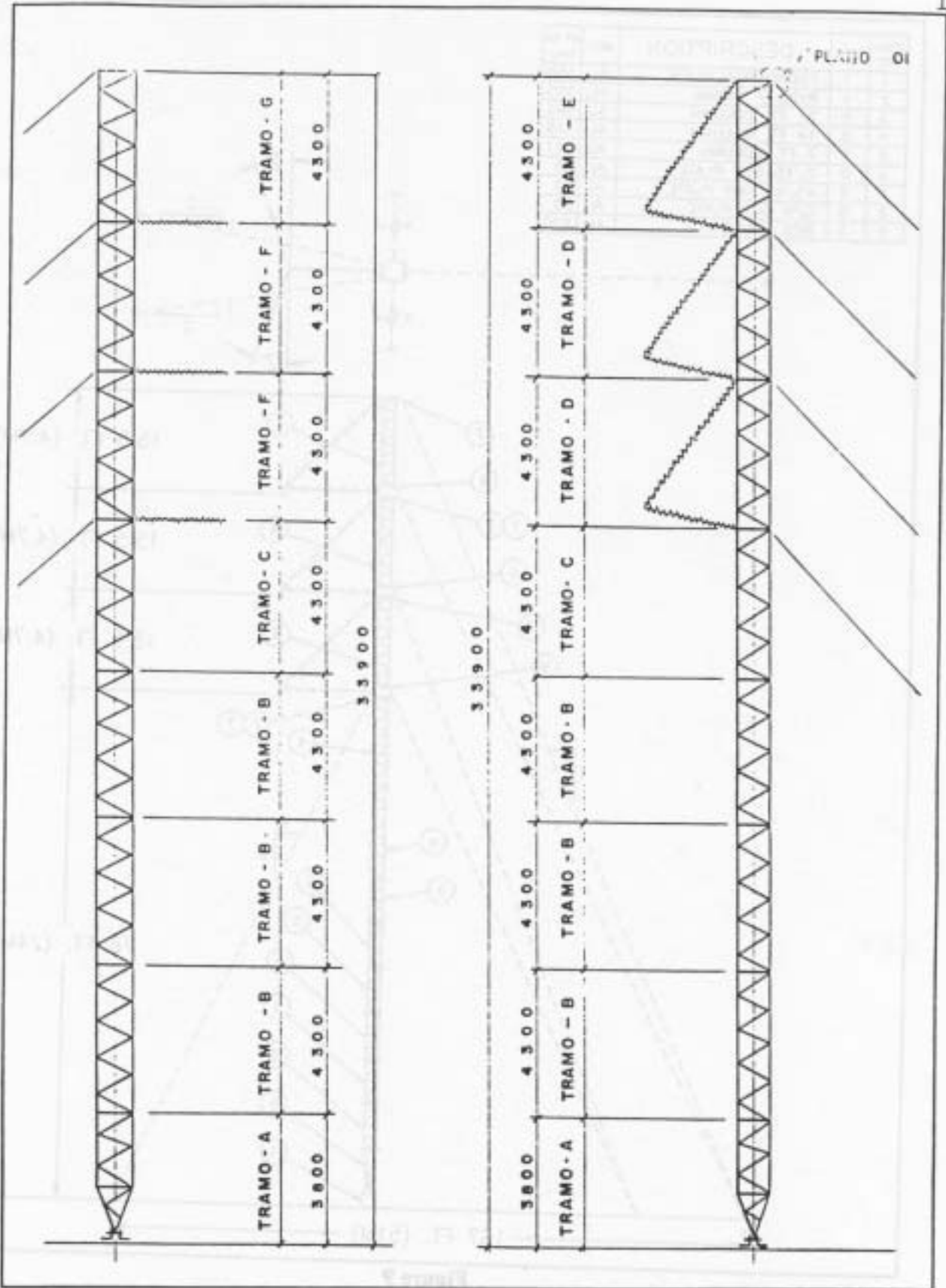

**Figure 8**  
*Modular Steel Structure (dimensions in millimeters).*

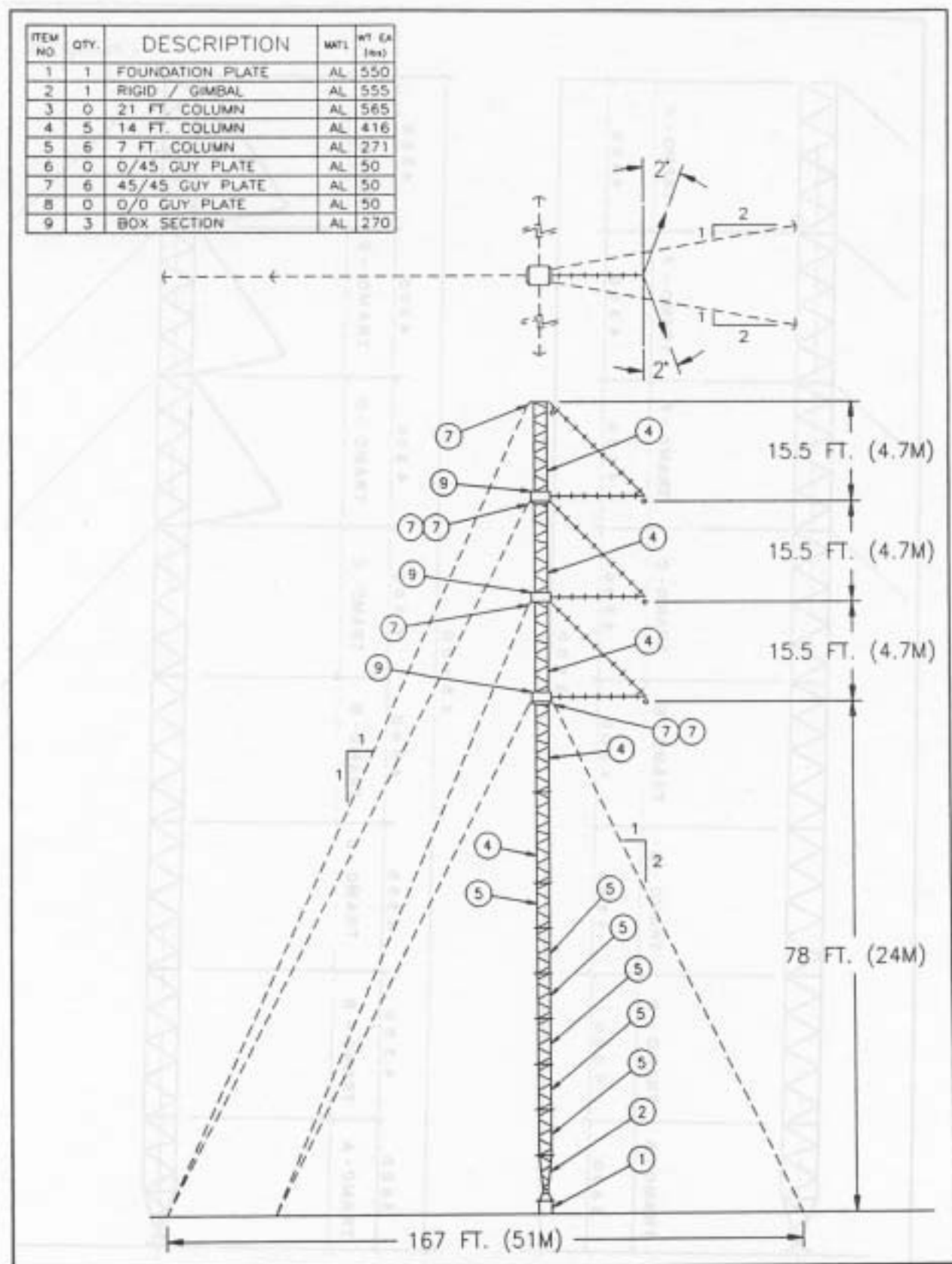

Figure 9

*Modular Aluminum Structure in a Horizontal Vee Configuration*

#### 4.5 Modular Aluminum Structures

In order to provide emergency structures for the 500kV line from San Carlos to Sabanalarga, ISA acquired a number of modular, aluminum restoration structures in 1986. These welded aluminum structures are made in modules of 7, 14 and 21 feet, allowing modifications in structure height and design depending on the requirements. The foundation consists of a 1 inch aluminum plate that is placed on the ground. Above the foundation is the gimbal joint that allows universal articulation and reduces the eccentricity of the column loads (Figure 9).

The modular components are lightweight, allowing transportation to remote and inaccessible sites either manually or by helicopter. Structures can be designed using the same basic components that are suitable for use at 115, 230 and 500kV, single or double circuit, horizontal or vertical phase spacing (Figure 10).

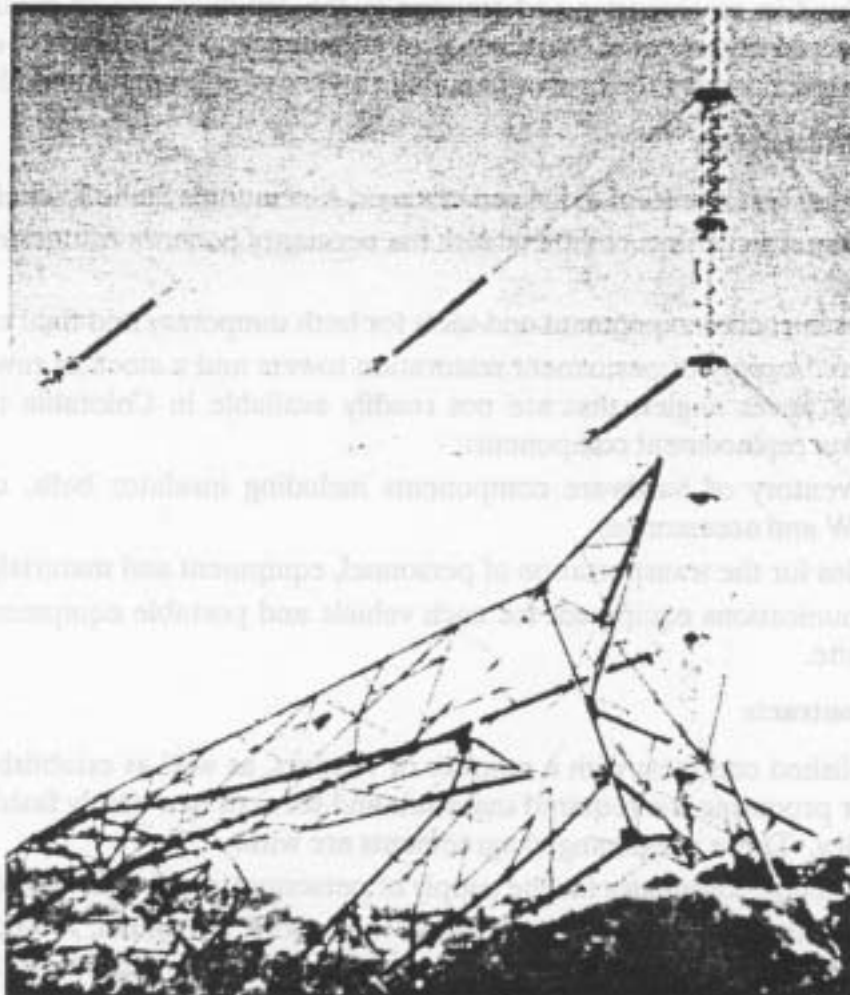

**Figure 10**

*ISA has designed a number of unique configurations using the modular, aluminum restoration structures, including this 500kV three phase running angle structure used to restore a sabotaged 90° tension structure. To get an idea of the scale, note the lineman working on the outer conductor bundle.*

## 5. Emergency Preparations

Due to the frequent emergencies, ISA has developed a number of strategies to insure rapid restoration, thus minimizing the economic and social impact.

### 5.1 Training of Personnel

Probably the most important measure that can be taken in preparing for emergencies is to train the personnel in the proper procedures for handling emergencies. For engineers and supervisors, this training involves becoming completely familiar with the *Emergency Plan* (Appendix A). Extensive training is done with the aluminum restoration structure design programs, methods for rapidly developing emergency structure designs and understanding the various factors involved in an emergency to enable recommendation of the most appropriate action.

For linemen and work crews, training consists of practice in the erection of various types of emergency structures and configurations. Also, frequent practice in the various work methods involved in emergencies and training in the optimum use of available resources insures efficiency and quickness at the time of an emergency. At all times during training, safety is emphasized, ensuring the proper handling and use of equipment and tools.

### 5.2 Emergency Materials

To insure the timely restoration of a downed tower, ISA maintains the following materials:

- Temporary structures complete with the necessary polymer insulators, guys and anchors;
- Line construction equipment and tools for both temporary and final restoration;
- A limited supply of permanent restoration towers and a stock of raw materials, such as tower angles, that are not readily available in Colombia in order to fabricate replacement components;
- An inventory of hardware components including insulator bells, conductors, OHGW and accessories;
- Vehicles for the transportation of personnel, equipment and material;
- Communications equipment for each vehicle and portable equipment for each work site.

### 5.3 Vendor Contracts

ISA has established contracts with a number of vendors, as well as established streamlined procedures for procuring the required materials and services in a timely fashion in the event of an emergency. These pre-arranged agreements are with:

- Construction companies for the supply of personnel, equipment and materials;
- Ground transportation companies to transport personnel, equipment and materials to accessible work sites or to staging areas near remote work sites;
- Air transportation companies to fly line inspections, as well as the transport of personnel, equipment and structures to remote work sites;
- Tower fabricators to make the required replacement components and new, permanent towers;

- Other utilities to provide mutual assistance including personnel, structures, equipment and hardware. These agreements also cover the sharing of training and restoration techniques.

#### **5.4 Military Protection**

When ISA first began to restore towers damaged as a result of sabotage, the difficulty of the task was compounded by the fact that the guerrillas viewed the repair workers as targets. The guerrillas would attempt to intimidate the workers by destroying their equipment and tools, at one time even blowing up a Bell-212 helicopter used to bring personnel to the site.

As a result, the military now secures the sabotaged tower sites prior to beginning any restoration work. The military inspects the sabotaged tower and removes any unexploded dynamite. The area around the tower is also examined and secured since the guerrillas sometimes booby trap these areas with land mines and hand grenades. In some instances, the guerrillas have sabotaged towers as a means of laying an ambush for the military. In these cases it has been necessary for the military to mount an air assault on the area to secure it prior to restoration.

#### **6. Protection of Tower Sites**

As a result of the extensive experience with guerilla attacks, ISA has considered a number of physical barriers to limit the access of the guerrillas to tower sites. Protection methods considered have ranged from mine fields around the tower sites, to electrified fences (energized inductively from the power line or by solar power), to trenches around the towers. One of the more extensive methods considered consisted of a first barrier of barbed wire with an inner electrified fence and a mine field in between. None of these methods has been used due to the high construction and/or maintenance cost as well as concern over unnecessary confrontation with the guerrillas and danger to innocent people.

#### **7. Conclusions**

As a result of guerrillas that view the National Interconnection System of Colombia as a military target, sabotaging some of the most remote and inaccessible sites, ISA has developed extensive emergency plans to insure rapid restoration. ISA has creatively used the available resources, including designing unique structures from standard modular restoration components, making use of collapsed towers as temporary structures and modifying line parameters such as bundling and style to accomplish emergency restoration.

The potential cost of an extended loss of the National Interconnection System in Colombia goes beyond mere economics. Though the effect of an outage on the national economy can be large, the social and political costs are often much higher.

The planning and preparations, maintaining a supply of materials and emergency towers, having prearranged contracts for materials and services and having trained personnel has allowed ISA to minimize the interruptions due to sabotage and has been a major benefit to the country.

## Appendix A

# Emergency Planning Guide

Listed below is a summary of the resources required for emergency restorations.

### 1. Human Resources

- Engineers
- Technicians
- Inspectors
- Linemen
- Laborers

### 2. General Services

- Food and Lodging
- Fuel
- Air Transport
- Ground Transport

### 3. Financial Resources

- Purchase Materials
- Contract Personnel
- Construction of Civil Works
- Rental of Equipment and Tools
- General Expenses

### 4. Permits

- Coordination with other Electric Companies
- Coordination with Land Owners for:
  - Cutting Vegetation
  - Tower Sites
  - Right-of-Way
  - Helicopter Landing Sites
  - Material Yards

### 5. Availability of Equipment and Tools

- Line Construction Equipment
- Communication Equipment
- Safety Equipment

## 6. Emergency Restoration Structures

- Strategically located "packages" of structures, insulators, guys anchors, etc.

## 7. Line Hardware

- Current inventory status of all required line hardware and accessories.

## 8. Aerial Inspection

- Locate Downed Tower Site
- Evaluate the Extent of Damage
- Determine the Required Work  
*(Photograph and/or videotape the site for later evaluation.)*

## 9. Calculation and Design

- Determine Appropriate Emergency Restoration Structure Type
- Analyze Structure to Verify Capabilities
- Locate Structure, Considering Final Restoration Requirements

## 10. Assembly and Construction Methods

- Assemble Section by Section in Place using Helicopter, or Gin Pole and Winch
- Assemble on Ground, Erect using Crane, Helicopter, or Gin Pole and Winch

## 11. On Site Activities

- Locate Restoration Structures and Anchors
- Construct Heliports and Material Yards
- Install Anchors
  - Treated Wood Pole
  - Metallic Plate or Screw Type
- Level Tower Site
- Position Foundation
- Mount Gimbal Section
- Erect Tower Modules with Construction Guys
- Install Guy Plates and Accessories
- Install Permanent Guys
- Tension Guys (preferably with a Dynamometer)
- Install Required Hardware and Insulators
- Install Conductor Repair Sleeves
- Replace Damaged Conductor Sections
- Install Conductors on Towers