

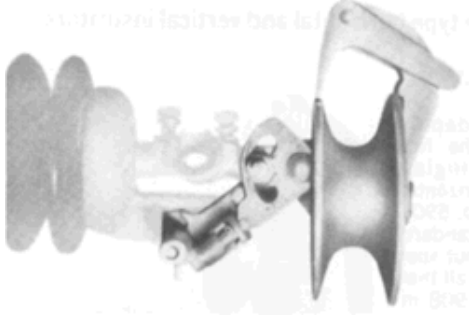

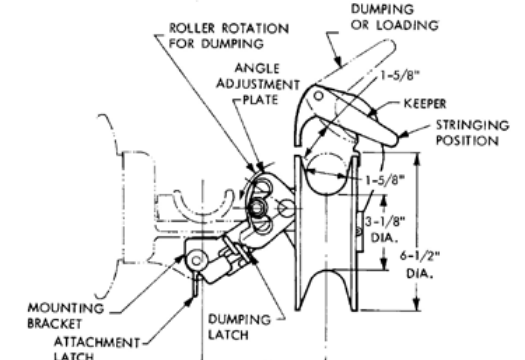
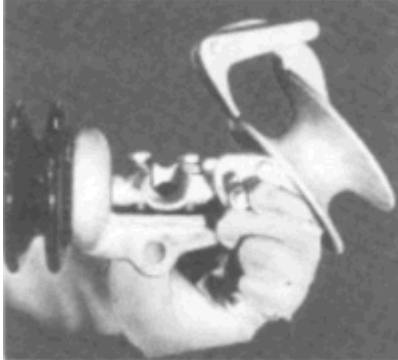
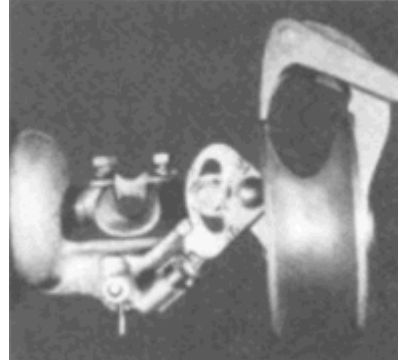

## Distribution stringing Rollers

**5326 Horizontal Dumping Roller** (For adapting No. 5902, 5903 and 5904 Rollers to clamp top type horizontal and vertical insulators.)

 <p>U.S. PATENT 3,235,228 and 3,889,911</p>	<p>This unique stringing tool enables one lineman to quickly transfer the conductor from the roller to the clamp with one hand, without removing the roller or lifting the conductor. The No. 5326 can be used on horizontal insulators or, with adapters on vertical insulators and cross arms.</p>	
		
<p><b>INSTALLATION</b></p> <p>The No. 5326 can be attached without tools, to most standard horizontal post insulators. Its lightweight (7 lbs.) makes it easy for one man to install it on the pole or on the ground.</p>		<p><b>STRINGING POSITION</b></p> <p>The deep-groove sheave rotates on maintenance-free ball bearings. The keeper assures confinement of the conductor for maximum safety.</p>
		
<p><b>DUMPING POSITION</b></p> <p>During transfer the conductor is safely confined between the roller and the clamp to prevent the conductor from being dropped. Dumping is easily done with one hand.</p>		<p><b>INSULATOR CLAMPED IN PLACE</b></p> <p>The No. 5326 can now be easily removed by one man.</p>

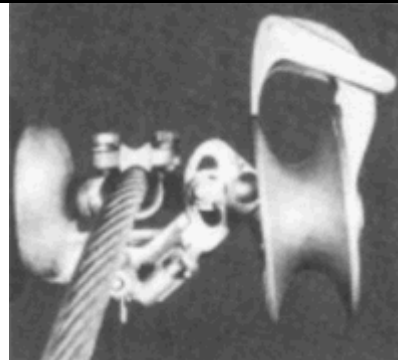
**5369 Heavy Duty Dumping Roller**

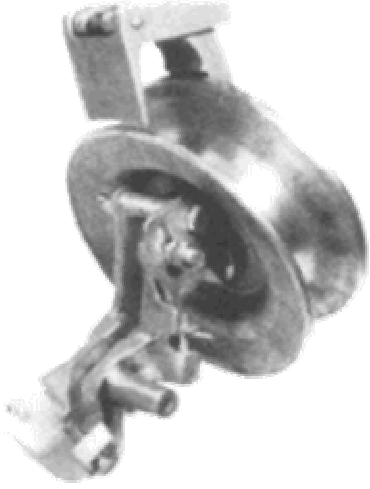
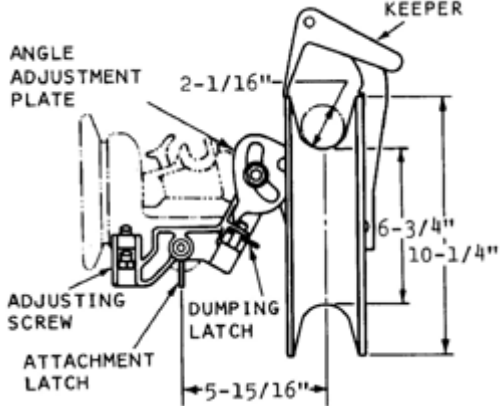
 <p>The No. 5369 Heavy Duty Dumping Roller makes it possible to string conductor on horizontal insulators then transfer it into the conductor clamp in one simple operation. (See description on No. 5326 above).</p>	<p>The No. 5369 has a 101/4" O.D., 63/4" I.D. and 21~16" diameter groove sheave. The angle of the sheave is adjustable to five positions.</p> <p>The part attaches to the insulator with a locking pin that goes through the insulator yoke lifting eye and adjustable bolts that rest under the insulator cap.</p> <p>Materials are lightweight, high strength 356-T6 aluminum alloy and cadmium plated ferrous parts. Sheaves are mounted on lubricated, double shielded ball bearings for maintenance-free operating life. Weight is 13 lbs.</p>	 <p>Technical drawing of the No. 5369 Heavy Duty Dumping Roller showing dimensions and labels:</p> <ul style="list-style-type: none"><li>ANGLE ADJUSTMENT PLATE</li><li>2-1/16"</li><li>KEEPER</li><li>6-3/4"</li><li>10-1/4"</li><li>ADJUSTING SCREW</li><li>DUMPING LATCH</li><li>ATTACHMENT LATCH</li><li>5-15/16"</li></ul>
--	---	---